

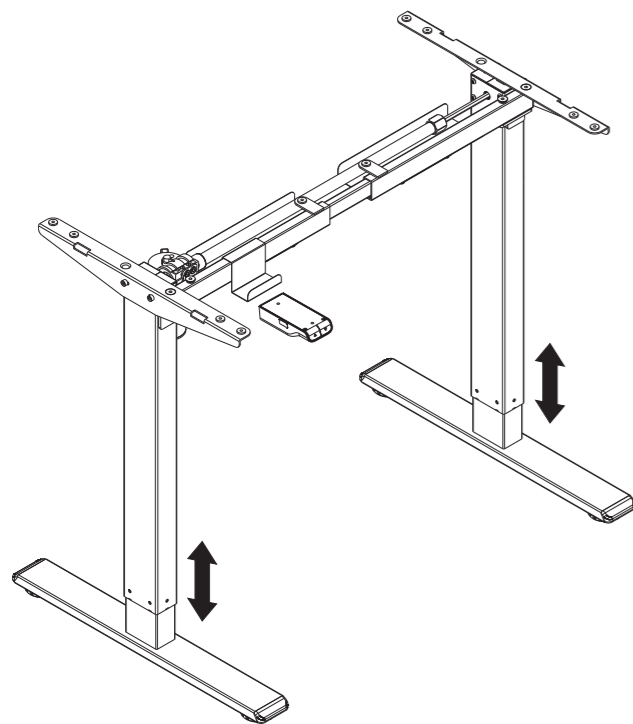

Item No.: HASD-114G-WH/BK/GY

Installation guide



Technical data

Column Number	2
Maximum Load	70KG
Max Speed	25mm/s
Input Voltage	100-240V
Lowest Position	710mm
Highest Position	1210mm
Desktop Size	1000-1600mm 500-800mm
Duty Cycle	10%(Pause 18 minutes for each continuous 2-minute operation)
Applicable Temperature	0~40°C

Accessory list

Attention: The drawings below are only for reference which might be slightly different from the actual object, please in kind prevail. Any tools missing or installation problems, please contact the customer service firstly.

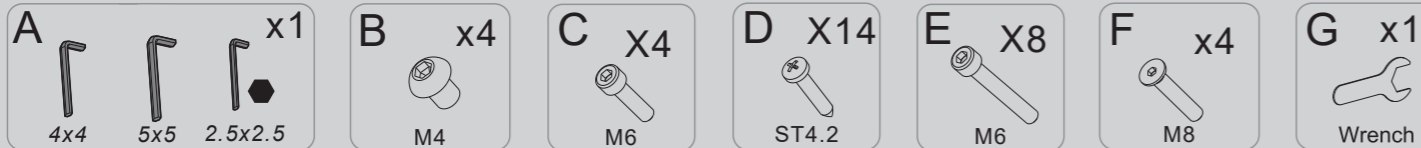

Part list

No.	Part	Qty	No.	Part	Qty	No.	Part	Qty
①	Pedestal	2	②	Left Column	1	③	Right Column	1
④	Supporting beam	1	⑤	Transmission rod	1	⑥	Supporting plate	2
⑦	Adapter	1	⑧	Baffle	2	⑨	Power cable	1
⑩	Cable tie	4	⑪	Adaptor holder	1	⑫	Handset	1
⑬	Switch cord	1						

Installation instruction

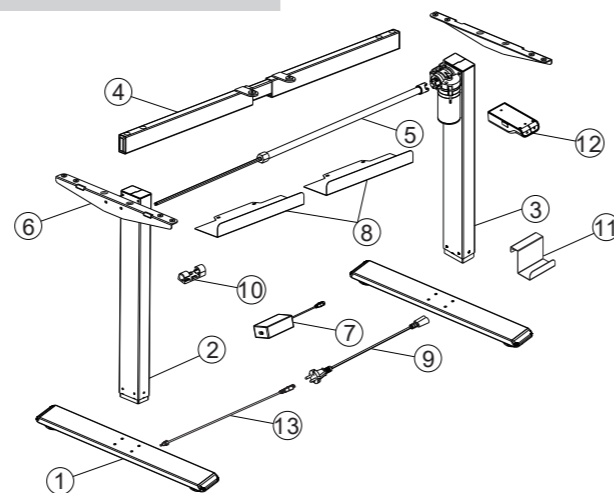

STEP1

Install Pedestal(1)

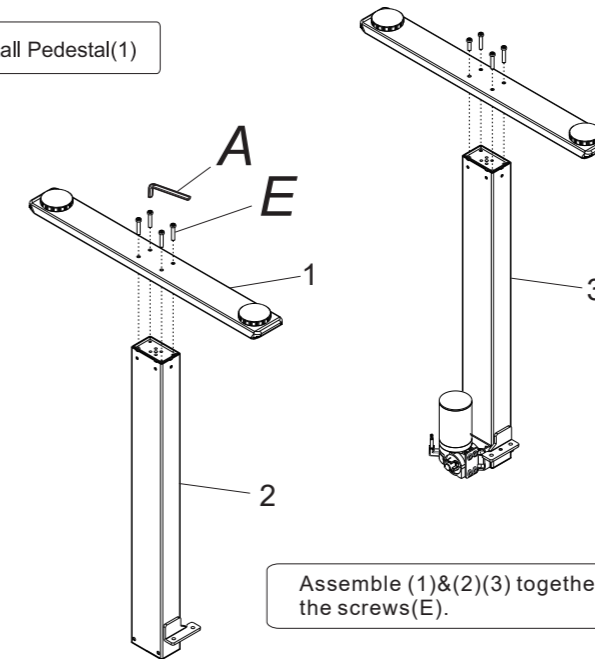

Assemble (1)&(2)(3) together, use the 5x5 allen key (A) to tighten the screws(E).

STEP2

Install Supporting beam(4)

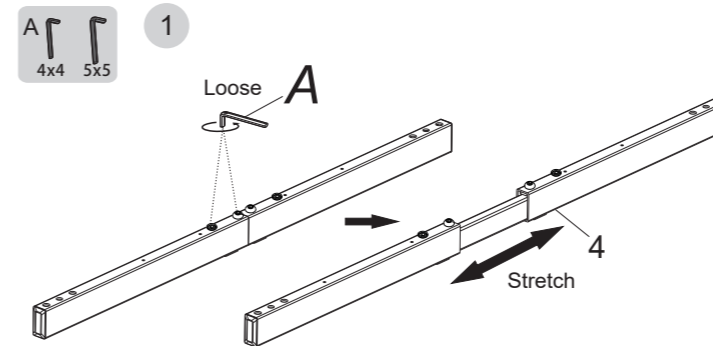

Unscrew the screws on supporting beam(4) with the 4x4 allen key (A), then stretch it (4).

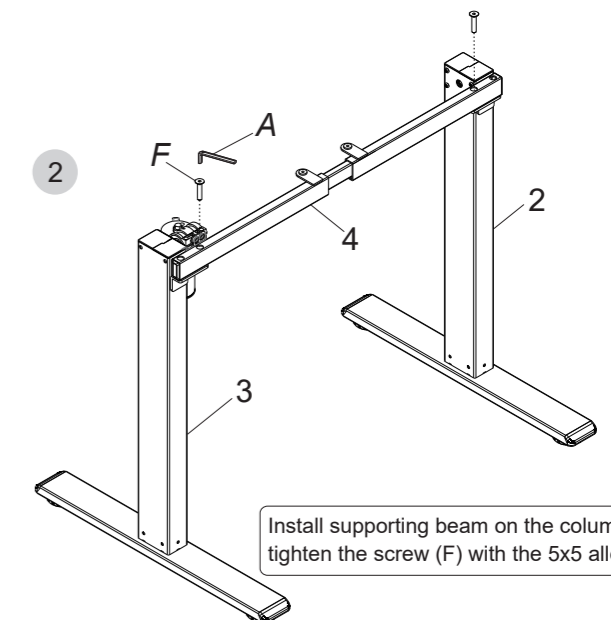

Install supporting beam on the columns(2)(3), tighten the screw (F) with the 5x5 allen key (A).

STEP3

Install transmission rod(5)

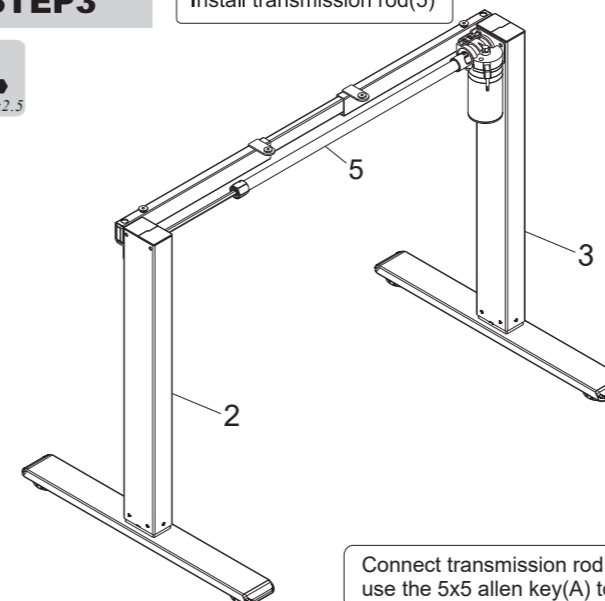
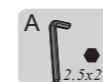

Connect transmission rod (5) with columns (2)(3), and use the 5x5 allen key(A) to tighten it.

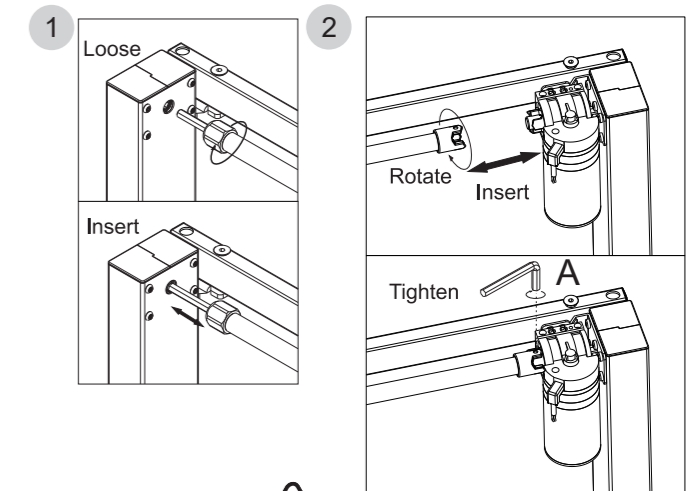

Do not rotate the angle exceed one third of the circle

STEP4

Install supporting plate(6)

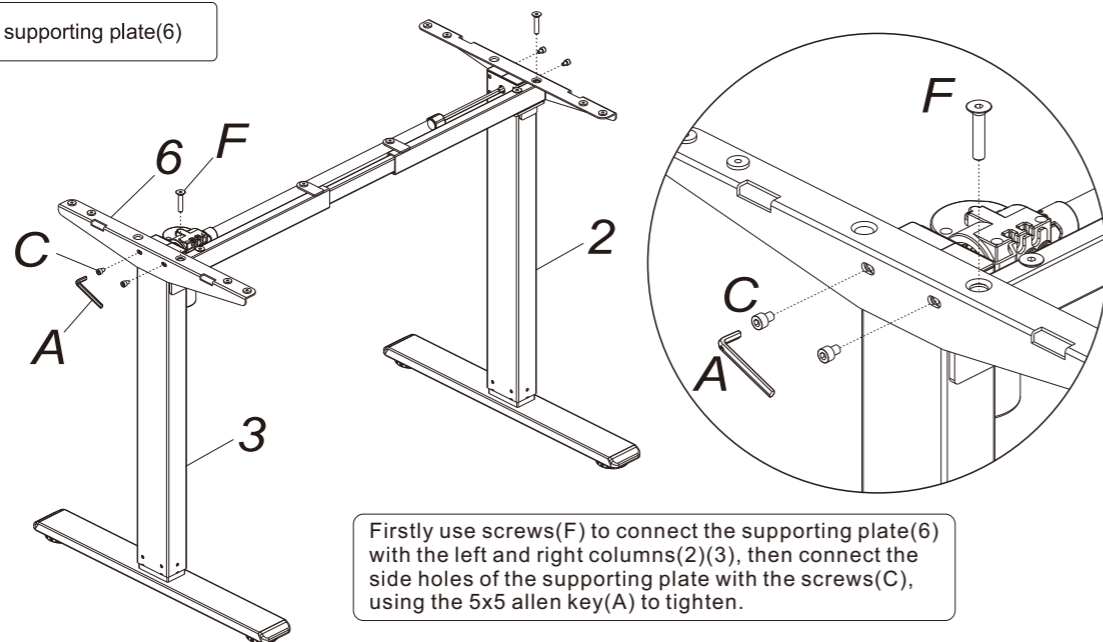

Firstly use screws(F) to connect the supporting plate(6) with the left and right columns(2)(3), then connect the side holes of the supporting plate with the screws(C), using the 5x5 allen key(A) to tighten.

STEP7

Install baffle and power adaptor

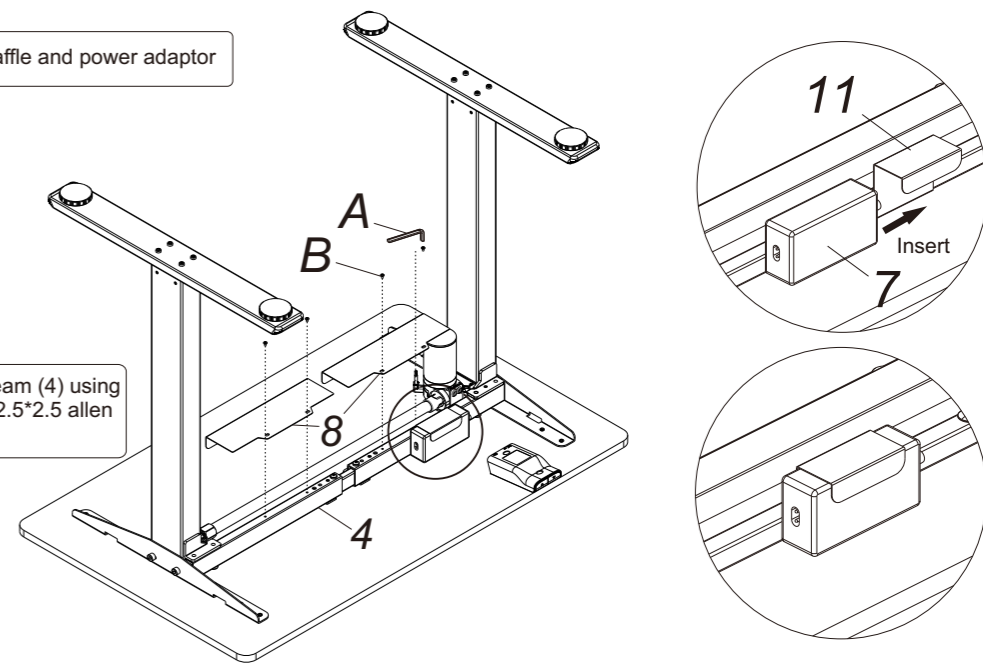
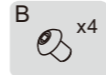

Install the baffle (8) to the supporting beam (4) using screws (B), and then tighten it with the 2.5*2.5 allen key (A).

STEP5

Install the power adaptor, tabletop and handset.



Connect the tabletop and the handset(12) with the screws (D), then tighten it with pistol electric drill.



Not included



Adjust the length of the supporting beam (4) according to the size of the table

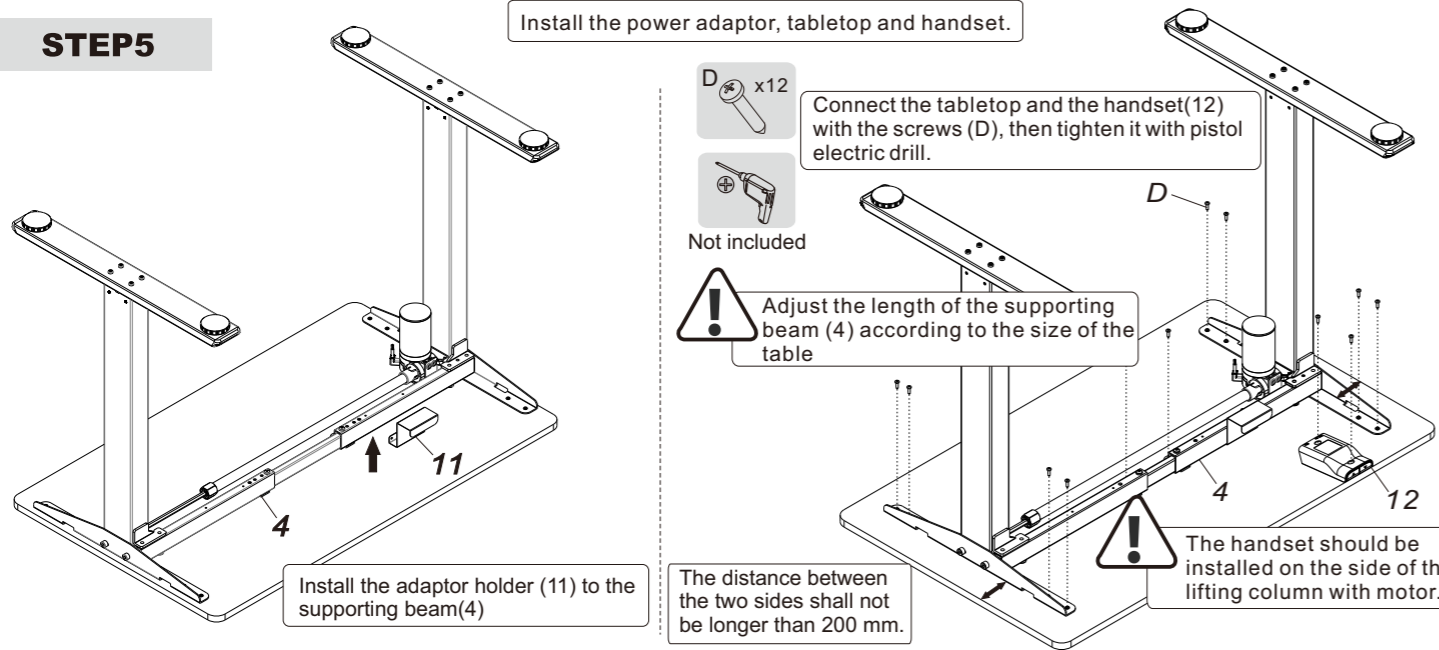

Install the adaptor holder (11) to the supporting beam(4)

The distance between the two sides shall not be longer than 200 mm.

The handset should be installed on the side of the lifting column with motor.

STEP8

Connect all cables to the adaptor (7)

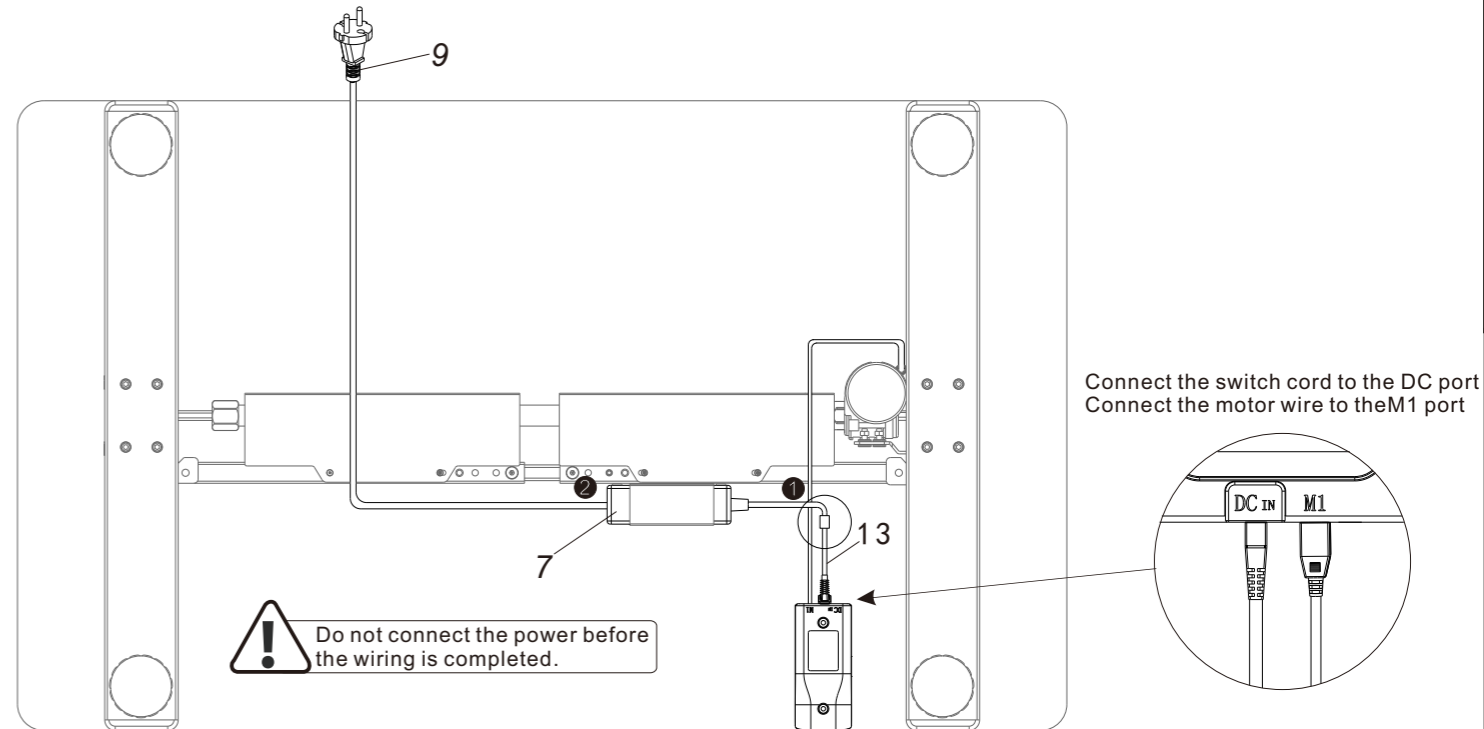

Do not connect the power before the wiring is completed.

Connect the switch cord to the DC port
Connect the motor wire to the M1 port

STEP6

Tighten the supporting beam and the transmission rod screw

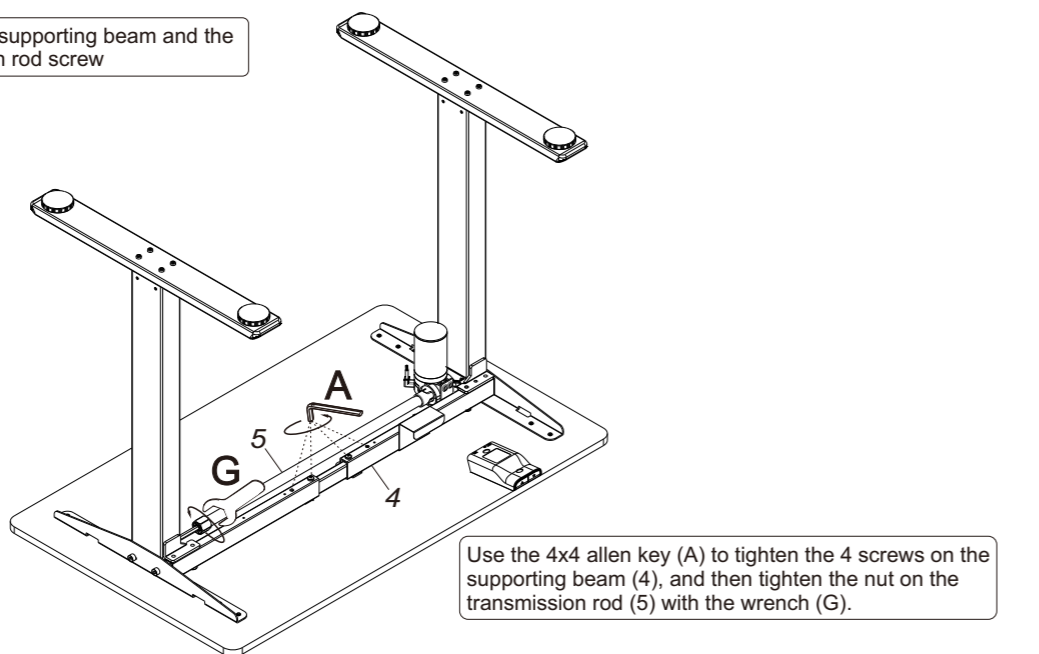

Use the 4x4 allen key (A) to tighten the 4 screws on the supporting beam (4), and then tighten the nut on the transmission rod (5) with the wrench (G).

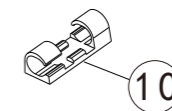
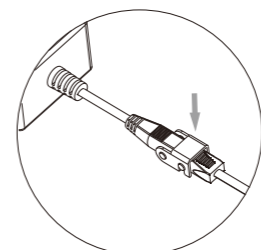
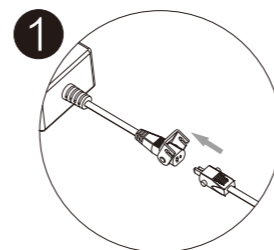

You can use the cable tie (10) to sort out the cables on the table to keep the cables tidy.

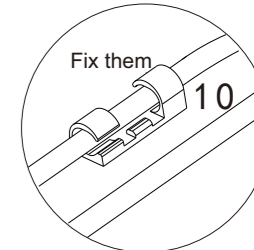
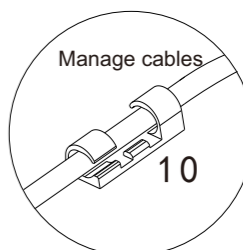
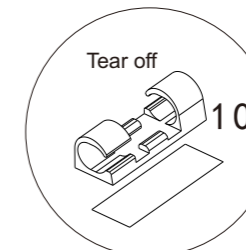
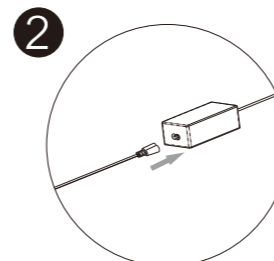

Common fault treatment

The following tips will help you detected and eliminate the common fault and error. If the fault you met is not listed below, please contact with your supplier. Only the manufacturer and professionals are capable for investigating and correcting those fault and error.

Fault phenomenon	Method
No response while long pressing down arrow after connected with a power supply	1. Check if all the cables be connected well
	2. Contact your supplier or dealer
No response while pressing up arrow/ down arrow after connected with a power supply	1. Check if all the cables be connected well
	2. Contact your supplier or dealer
Rising in a low speed	1. Check if overloaded, max loading: 70kg;
	2. Contact your supplier or dealer
The motor not move as instructed	1. Contact your supplier or dealer
Go down but not go up	1. Reset
	2. Contact your supplier or dealer
Downward sliding	1. Check if overloaded, max loading: 70kg;
	2. Contact your supplier or dealer
Frequently Reset	1. Check if overloaded, max loading: 70kg;
	2. Contact your supplier or dealer
Overwork (Duty cycle : Max 2min on/18min OFF)	1. Restart after suspend for 18mins while connecting with power;
	2. Contact your supplier or dealer;
Not enough up&down height	1. Reset
	2. Contact your supplier or dealer



Attention

1. Power supply: AC100V-240V,50/60Hz
2. Service Environment: 0-40℃
3. Unplug the power plug before cleaning, wipe the dust on surface with slight wet dishcloth when cleaning, be careful not to let the drops into the internal parts, not loose the connector.
4. The electric box contains electronic components, metals, plastics, wires etc., so dispose of it in accordance with each country's environmental legislation, not the general household waste.
5. Check carefully to ensure correct and complete assembly before using.
6. Be familiar with all functions and program settings of the product before first use.
7. Children are forbidden to play on the product because of unforeseen action when playing, so any dangerous consequences caused by this improper action will not be on manufacturers.
8. Slight noise caused by the V-ribbed belt or brake system due to structure will not have any effect on the use of the equipment.
9. Corrosive or abrasive materials are forbidden to clean the equipment. Must ensure that the cleaner used will not pollute the environment.
10. This appliance can be used by children aged from 8 years and above and persons with reduced physical, sensory or mental capabilities or lack of experience and knowledge if they have been given supervision or instruction concerning use of the appliance in a safe way and understand the hazards involved. Children shall not play with the appliance.
11. Cleaning and user maintenance shall not be made by children without supervision.
12. If the supply cord is damaged, it must be replaced by the manufacturer, its service agent or a similarly qualified person in order to avoid a hazard.
13. Please make sure there is no hazard sources in your operating environment. e.g., do not litter the tools around. Always be careful to treat the packaging materials in order to avoid any possible danger, e.g. plastic bag may lead to choking hazard to children.
14. Keep the original package of the equipment if necessary in case of the future use in transportation.

Waste disposal

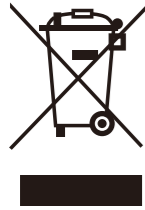

This marking indicates that this product should not be disposed with other household wastes. To prevent possible harm to the environment or human health from uncontrolled waste disposal, recycle it responsibly to promote the sustainable reuse of material resources. To return your used device, please use the return and collection systems or contact the retailer where the product was purchased. They can take this product for environmental safe recycling.