

ASSEMBLY DIAGRAM

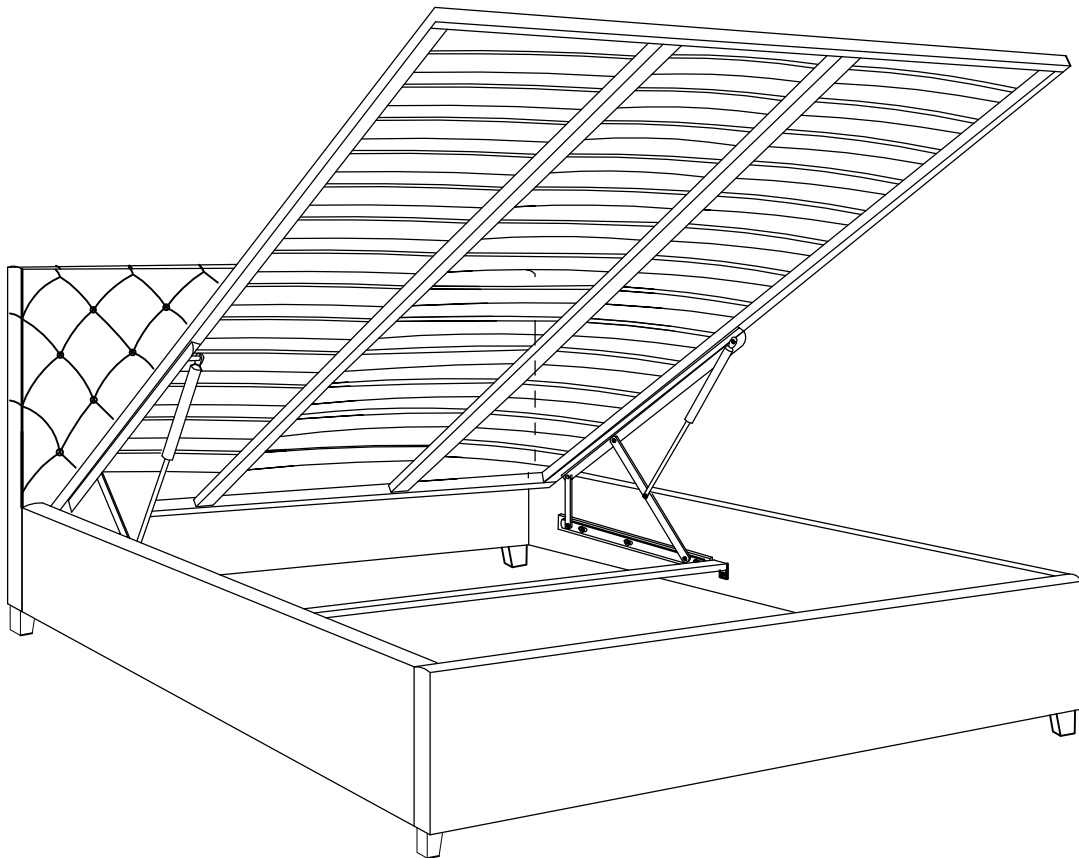





ISSA GAS LIFT BED FRAME

IMPORTANT NOTE:

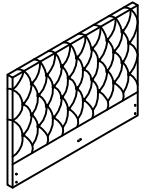
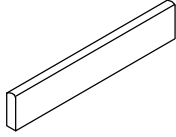
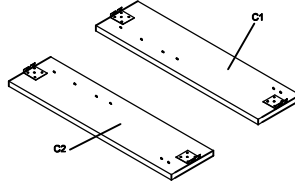
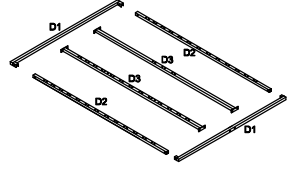
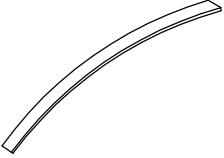

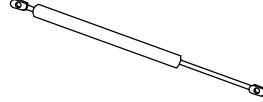
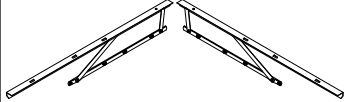

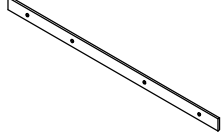
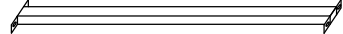
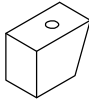

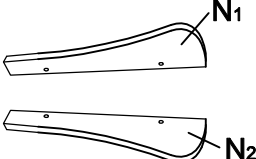



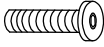

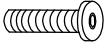
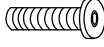

- ※PLACE ALL PARTS ON A CLEAN AND SMOOTH SURFACE SUCH AS A RUG OR CARPET TO AVOID THE PARTS FROM BEING SCRATCHED.
- ※KINDLY FOLLOW THE ASSEMBLY INSTRUCTIONS STEP BY STEP.
- ※DO NOT TIGHTEN ALL SCREWS UNTIL THE BED IS FULLY SET-UP.

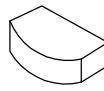
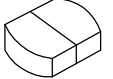

Parts List

A: HEAD BOARD 1PC 	B: FOOT BOARD 1PC 	C: SIDE RAIL 2PCS 	D: BEDSTEAD KD 1SETS 
E: SLAT 39PCS 	F: ANGLE IRON 2PCS 	G: STEAM MOVING BAR 2PCS (ASSEMBLED WITH H ALREADY) 	H: STEAM MOVING MECHANICA 2PCS 
I: SQUARE TUBE 2PCS 	J: THIN WOODEN PLATE 2PCS 	K: 1PC 	L: LEG 4PCS 
M: Non-Woven Bed Base 1PC 	N: WINGS 2PCS 		

Hardware List

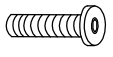
1: BOLT 26PCS  M8X45mm	2: BOLT 8PCS  M8X30mm	3: BOLT 8PCS  M6X40mm	4: BOLT 12PCS  M6X20mm	5: ALLEN KEY 1PC 	6: NUT 18PCS  M8
7: FLAT WASHER 38PCS  M8	8: SPRING WASHER 38PCS  M8	9: ALLEN KEY 1PC  M8	10: SPANNER 1PC 	11: SLAT CAP 26PCS 	12: DOUBLE PLASTIC CAP 26PCS 
13: ANGLE IRON 2PCS 	14: ALLEN KEY 1PC  M6	15: FLAT WASHER 20PCS  M6	16: SPRING WASHER 20PCS  M6	17: 1PC 	18: BOLT 4PCS  M8X55mm

STEP 1

1  4PCS

7  4PCS

8  4PCS

9  1PC

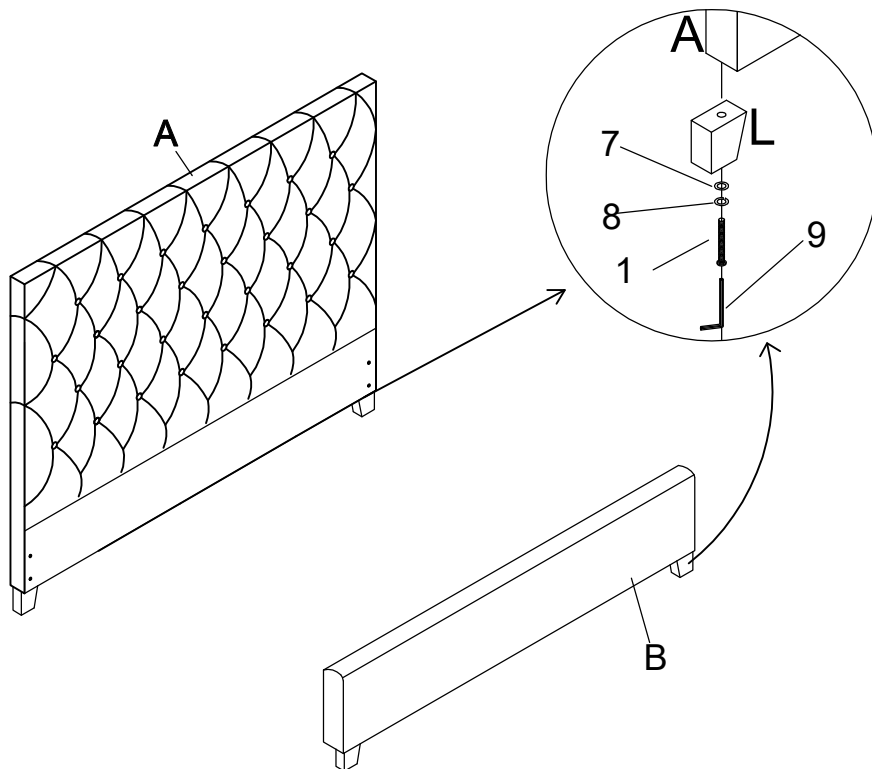

STEP 2

2  8PCS

7  8PCS

8  8PCS

9  1PC

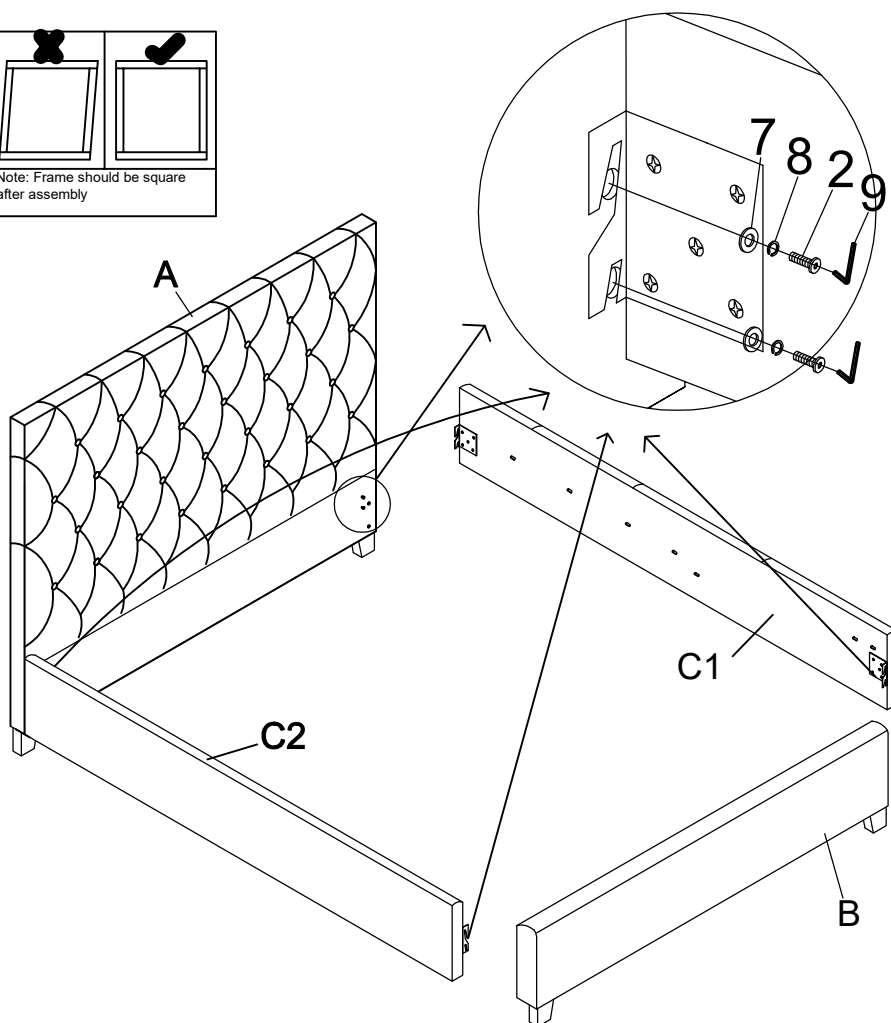
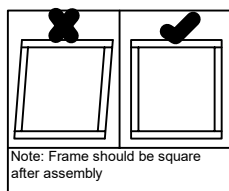

STEP 3

3  8PCS

15  8PCS

16  8PCS

14  1PC

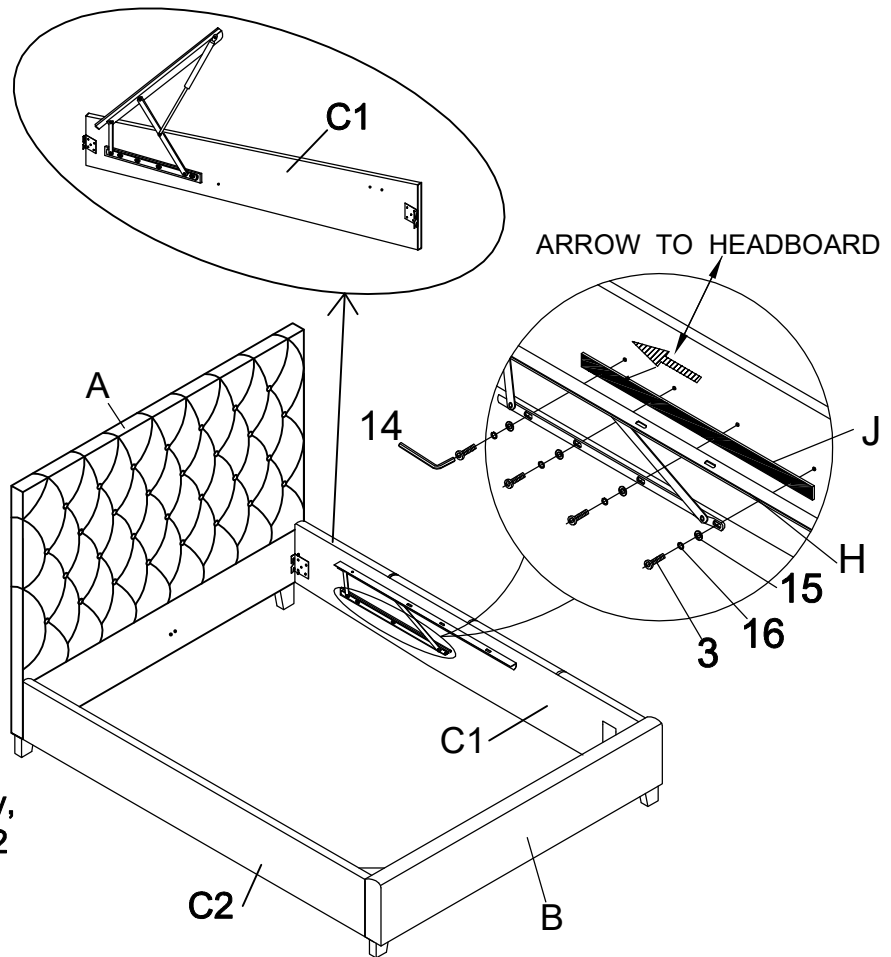

STEP 4

4  4PCS

15  4PCS

16  4PCS

14  1PC

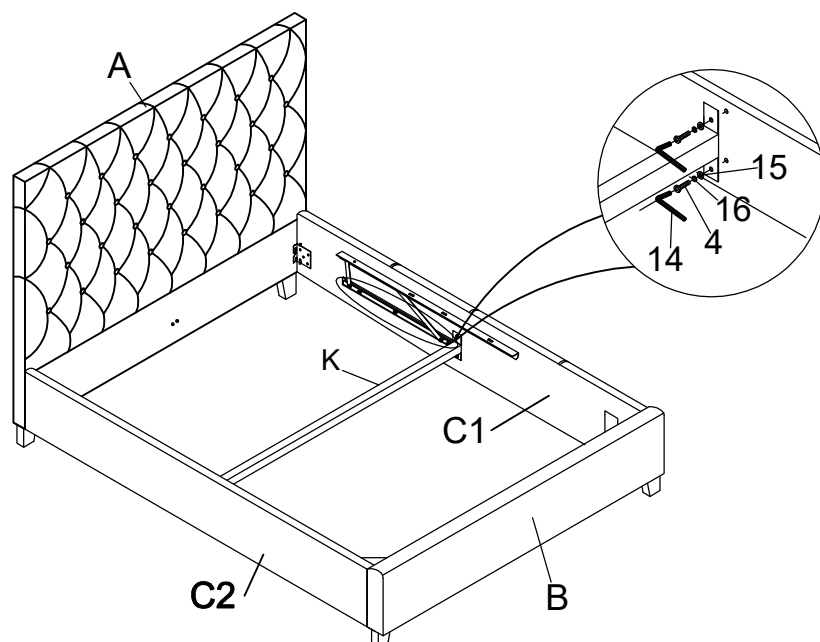



STEP 5

18  4PCS

7  4PCS

8  4PCS

9  1PC

1  2PCS

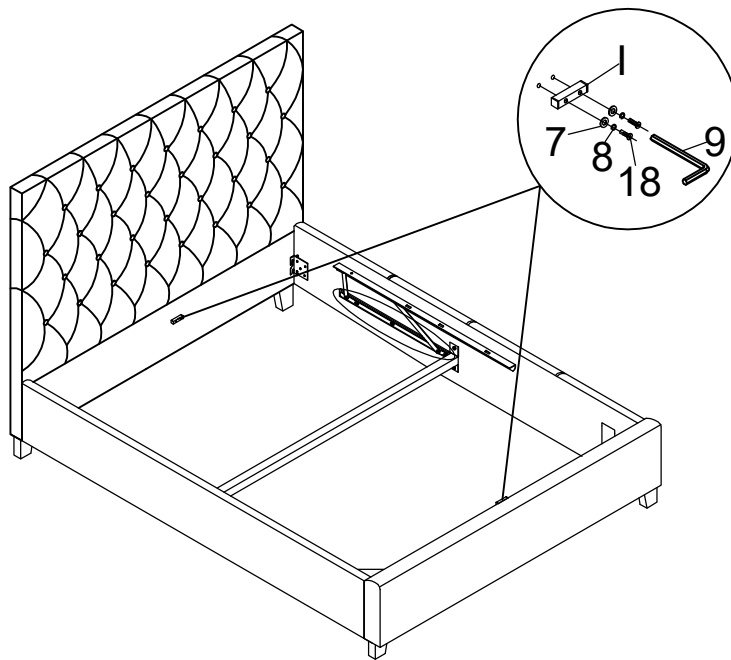

STEP 6

4  8PCS

15  8PCS

16  8PCS

14  1PC

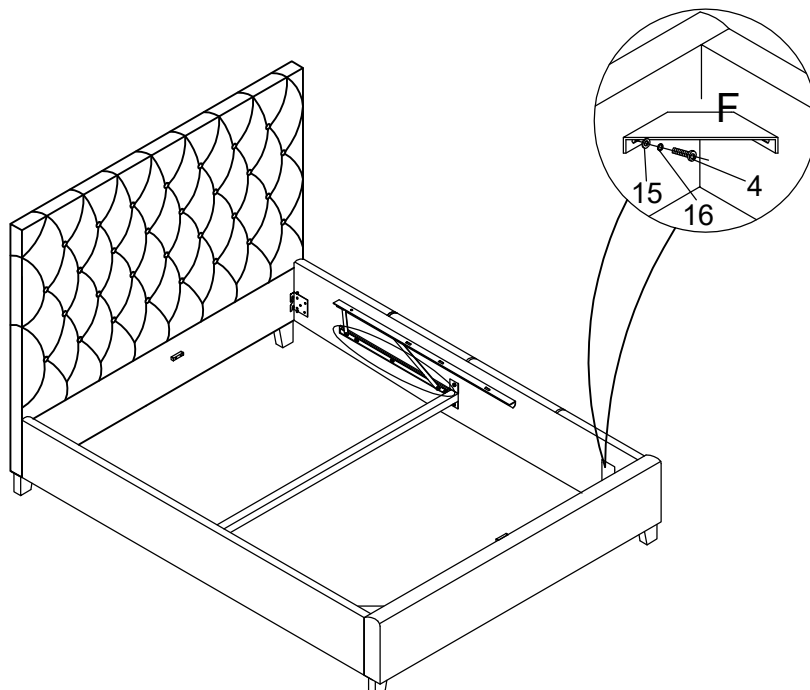

STEP 7

1  14PCS

7  14PCS

8  14PCS

6  14PCS

9  1PC

10  1PC

13  2PCS

17  1PCS

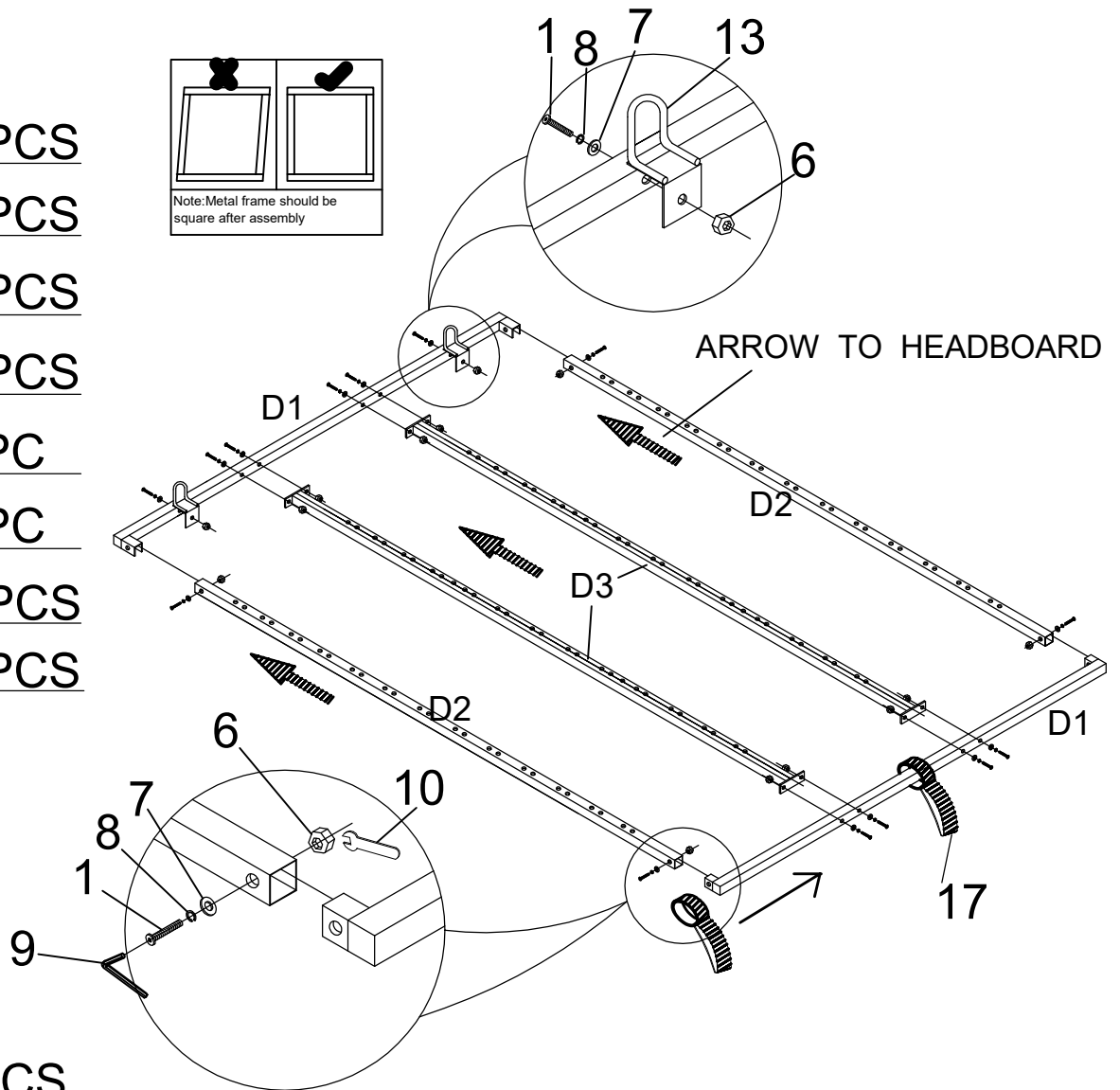
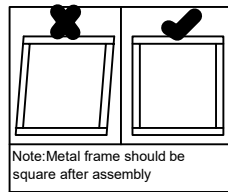

STEP 8

1  4PCS

7  4PCS

8  4PCS

6  4PCS

9  1PC

10  1PC

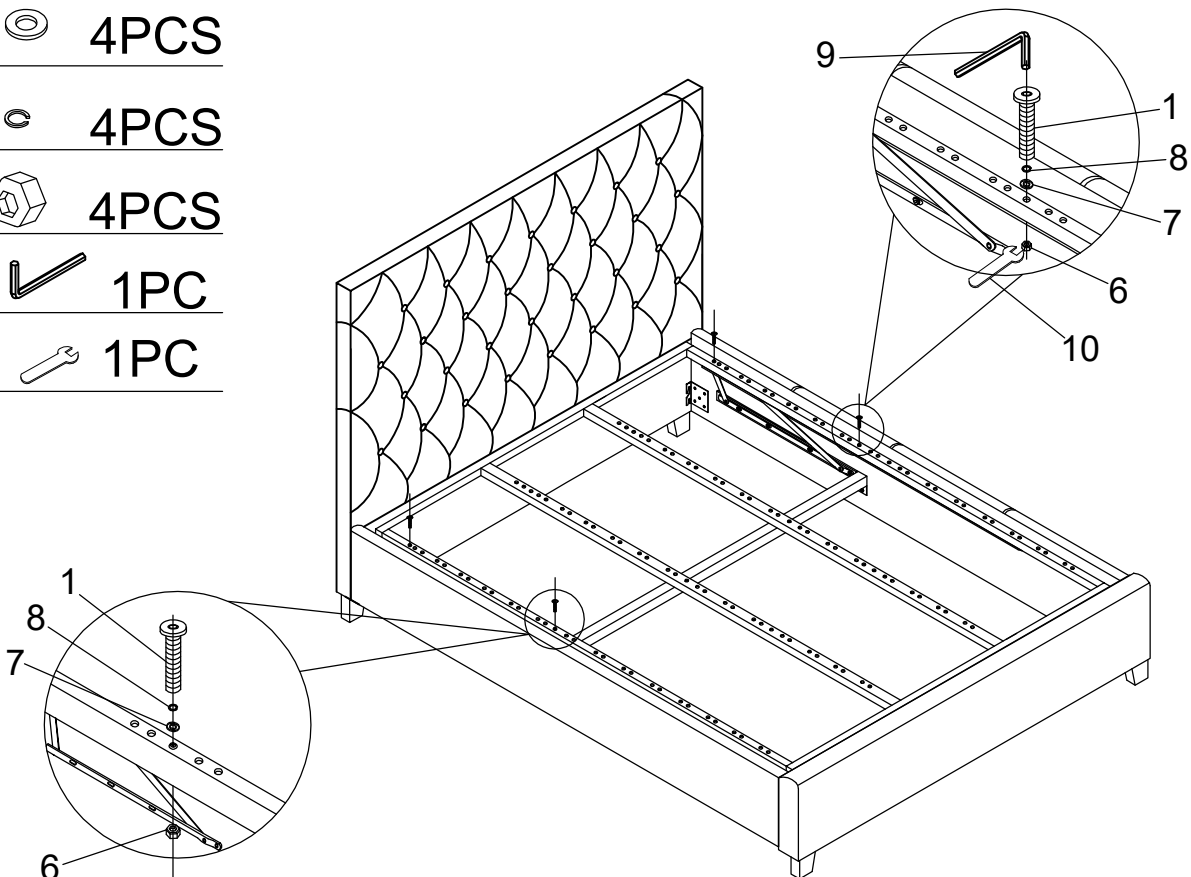

STEP 9

11  26PCS

12  26PCS

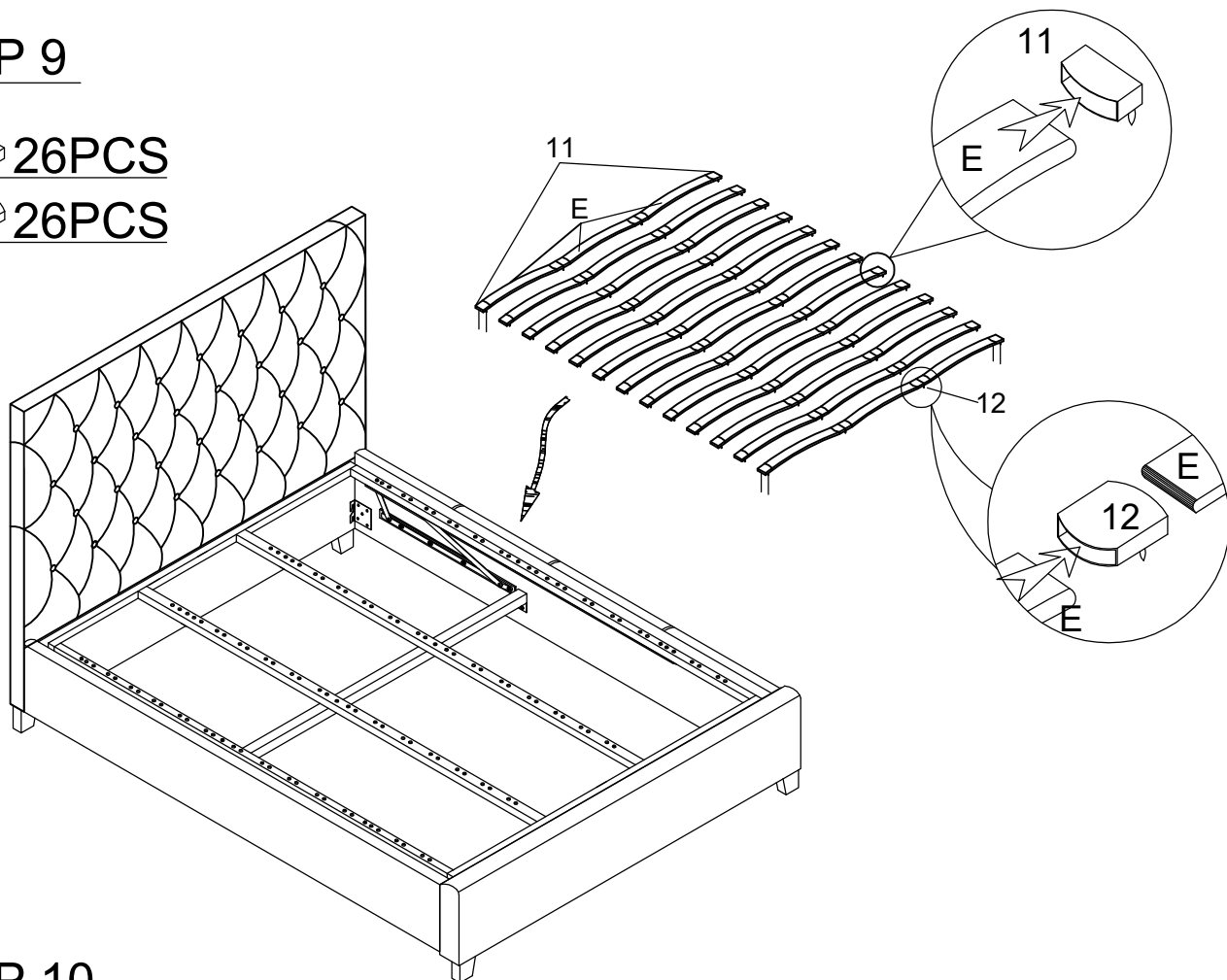

STEP 10

5  1PC

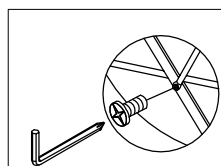
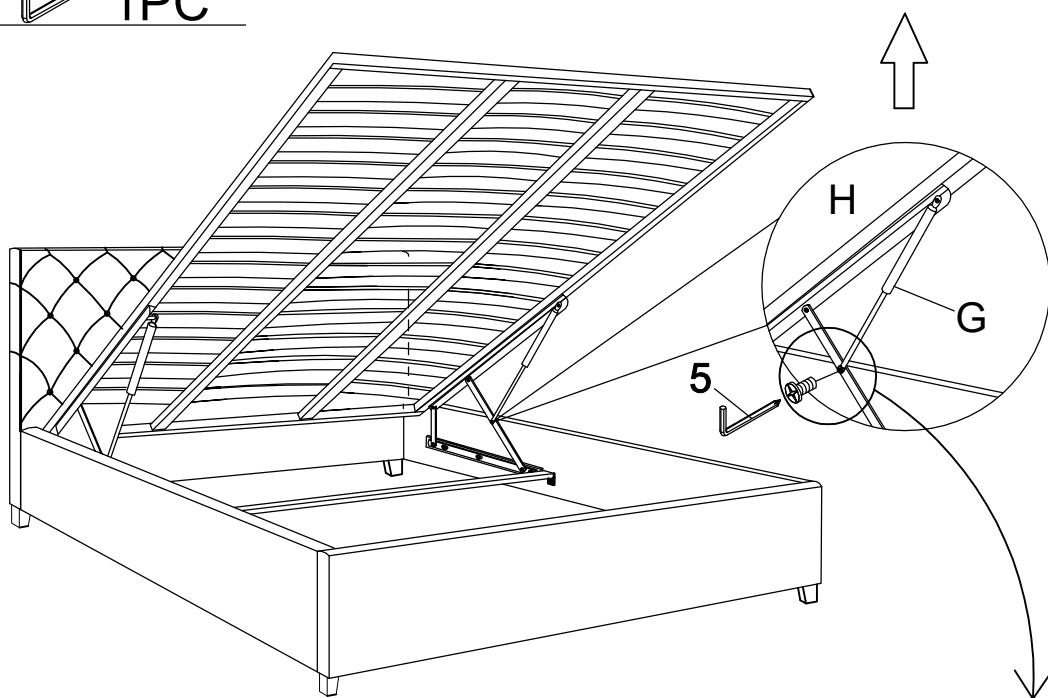



Lifting the base, remove the bolt shown (1pc) from Part H. ensuring that the base is supported and will not come down. Screw the bolt back in tightly

STEP 11

1  4PCS

7  4PCS

8  4PCS

9  1PC

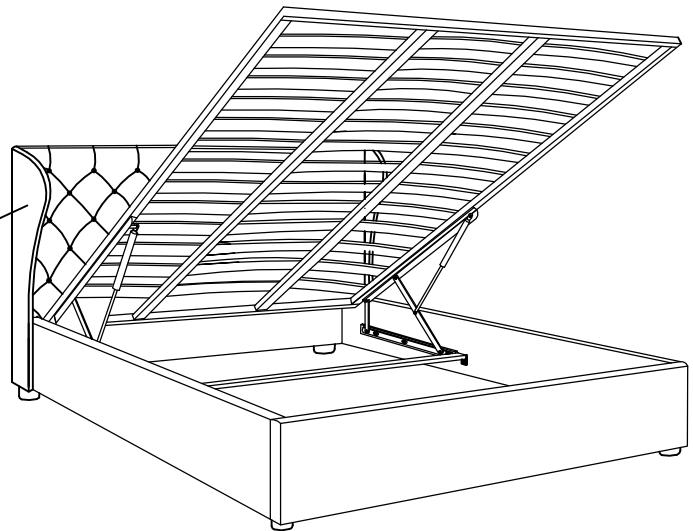
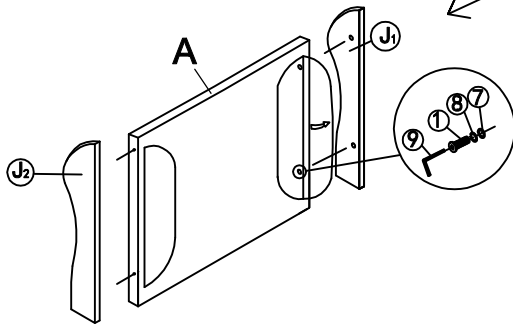

TAKE OFF THE WINGS FROM THE BACK OF HEADBOARD

STEP 12

M  1PC

